

# FORFORTH

*Products & Projects*

# FORTVNY®

FORTVNY and VENETIA STUDIUM are two faces of a single coin, two names coming together in an extraordinary cultural project reviving the elegance of early 20th century tastes in the design of lamps.

FORTVNY® lamps are produced exclusively by Venetia Studium, the only company in the world entitled to use the trademark.

Sophistication, refined techniques, a high quality finish and attention to detail are the distinctive features of each original lamp bearing the FORTVNY® trademark.

## FORTUNY® SILK LAMPS

### SCHEHERAZADE



### SCUDO SARACENO

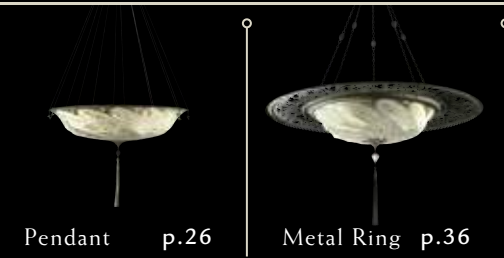

### SAMARKANDA



### CESENDELLO

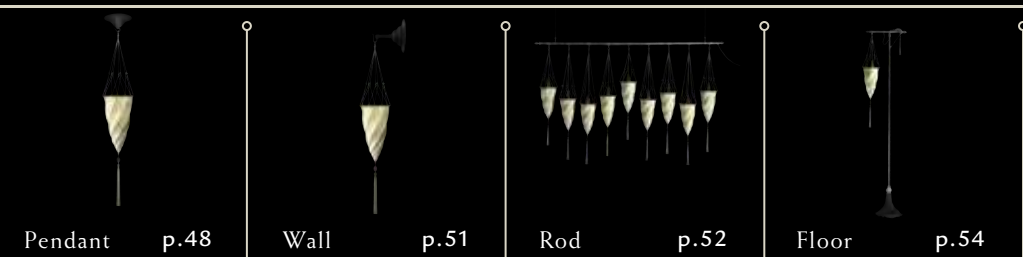

### CONCUBINE



## FORTUNY® GLASS LAMPS

### SCUDO SARACENO

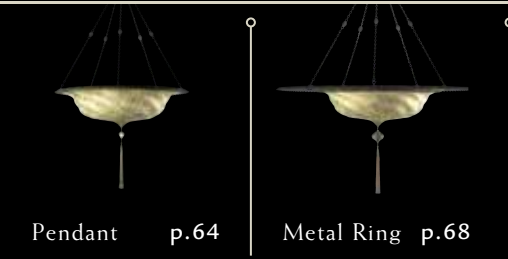

### SAMARKANDA



### CESENDELLO

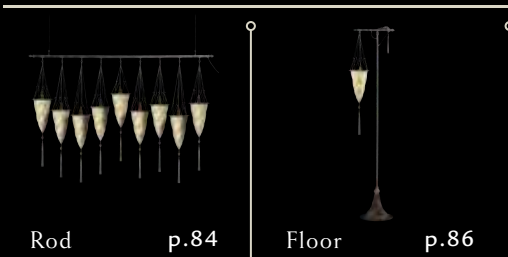
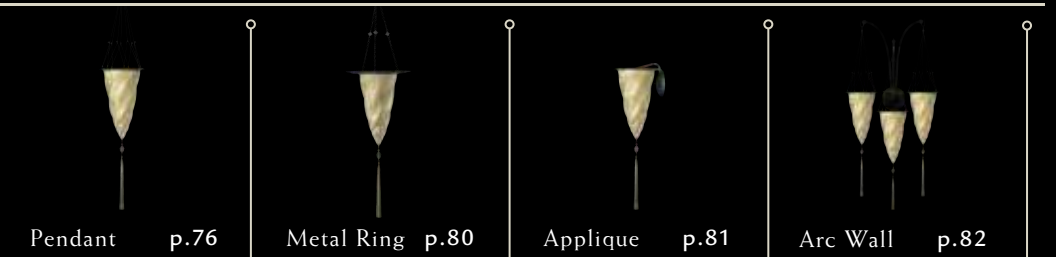

### COMPOSITIONS

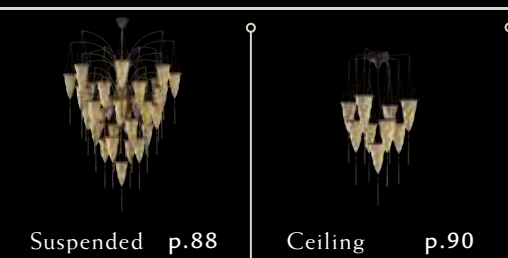





## SILK LAMPS

The lightness of the opaline silk, the refined decoration and the balance of the silhouettes merge together, creating true sculptures of light.

Perpetuating the tradition, Venetia Studium continues to produce these wonderful lamps.

Evoking almost fairytale places and times, FORTUNY® lamps are the result of research into lighting, design and ways of filtering light.

Thanks to the particular structure and various models proposed, they fit in with any style of décor, completely satisfying the needs of good illumination and giving the space a soft, evocative and timeless atmosphere.





Photo: Julie Soefer . Interior Design: Slovack-Bass

## SCHEHERAZADE

This lamp's name reflects the atmosphere it creates: a mixture of excitement and magnificence, along with intelligence and romance.

It combines Mariano Fortuny's love for combining the Venetian and the Oriental.

The elegant 3-tier structure has the form of an upside-down pagoda and is suspended by a delicate net of cords decorated with Murano glass beads.

The lower tier culminates with a fine engraved drop







Photo: Phillip Ennis . Interior Design: Slovack-Bass



Photo: Julie Soefer . Interior Design: Slovack-Bass









Photo: Casey Dunn . Interior Design: Risinger & Co.



Interior Design: Abby Smith Design





**Art. 126 SH**

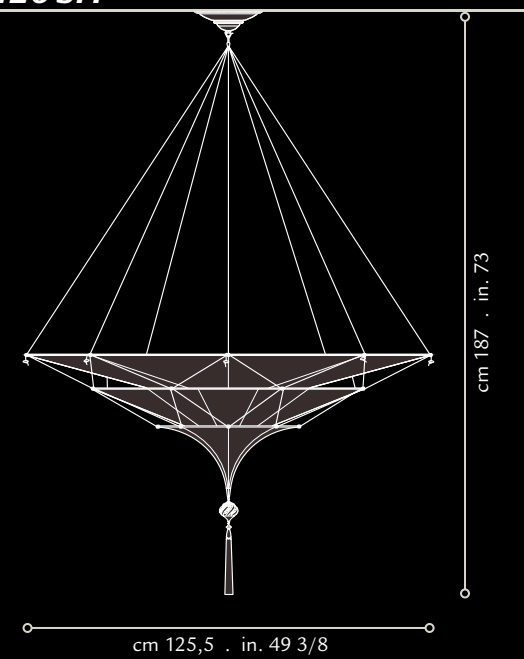

Structure: brass  
 Shade: pure silk fabric, murano glass beads  
 Weight: kg 4,4 . lb.9 oz.11  
 Wattage: suspended version 4 x max100W  
 flush mounted version 1 x max100W  
 Voltage: E26 socket 110V . E27 socket 220/240V  
 also suitable for LED light bulbs

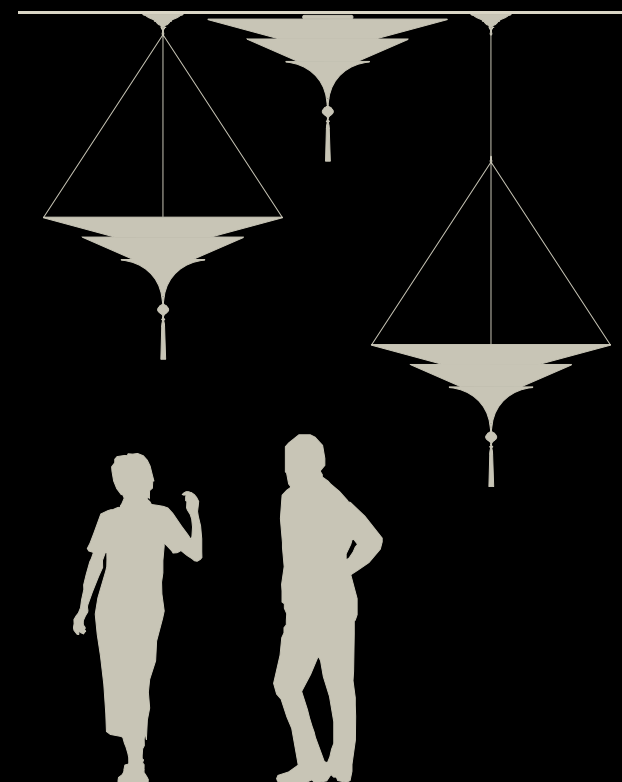

Geometric

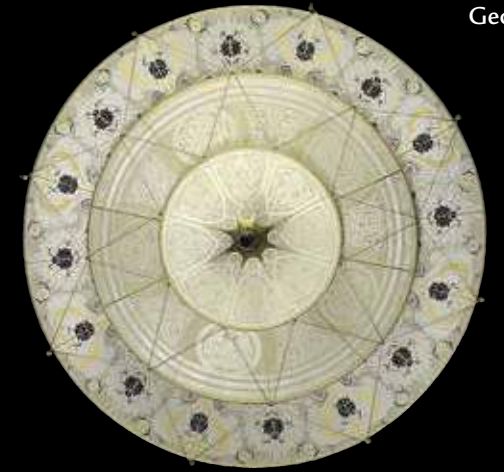

Floral

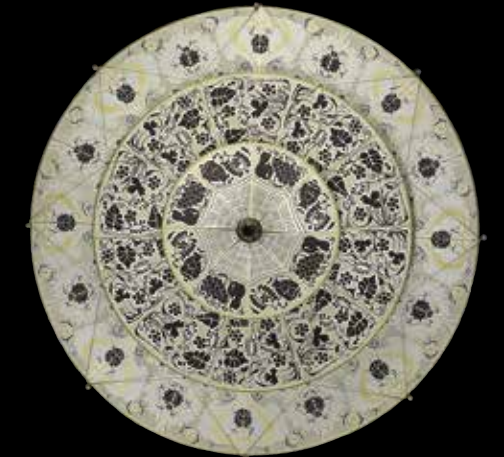

Herbarium



Plain

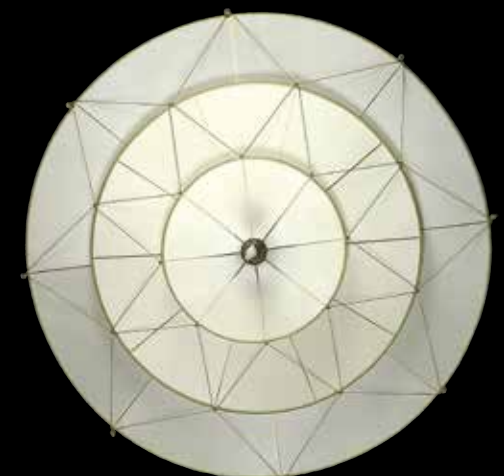





## SCHEHERAZADE 2 TIERS

A lamp with an evocative name conjuring up the magnificence of the Orient.

In the two tiers Scheherazade, Oriental style elements combine with Venetian-Saracen decorative motifs.

The lower tier culminates with a fine engraved drop.





Photo: Durston Saylor . Interior Design: David Scott Parker Architects

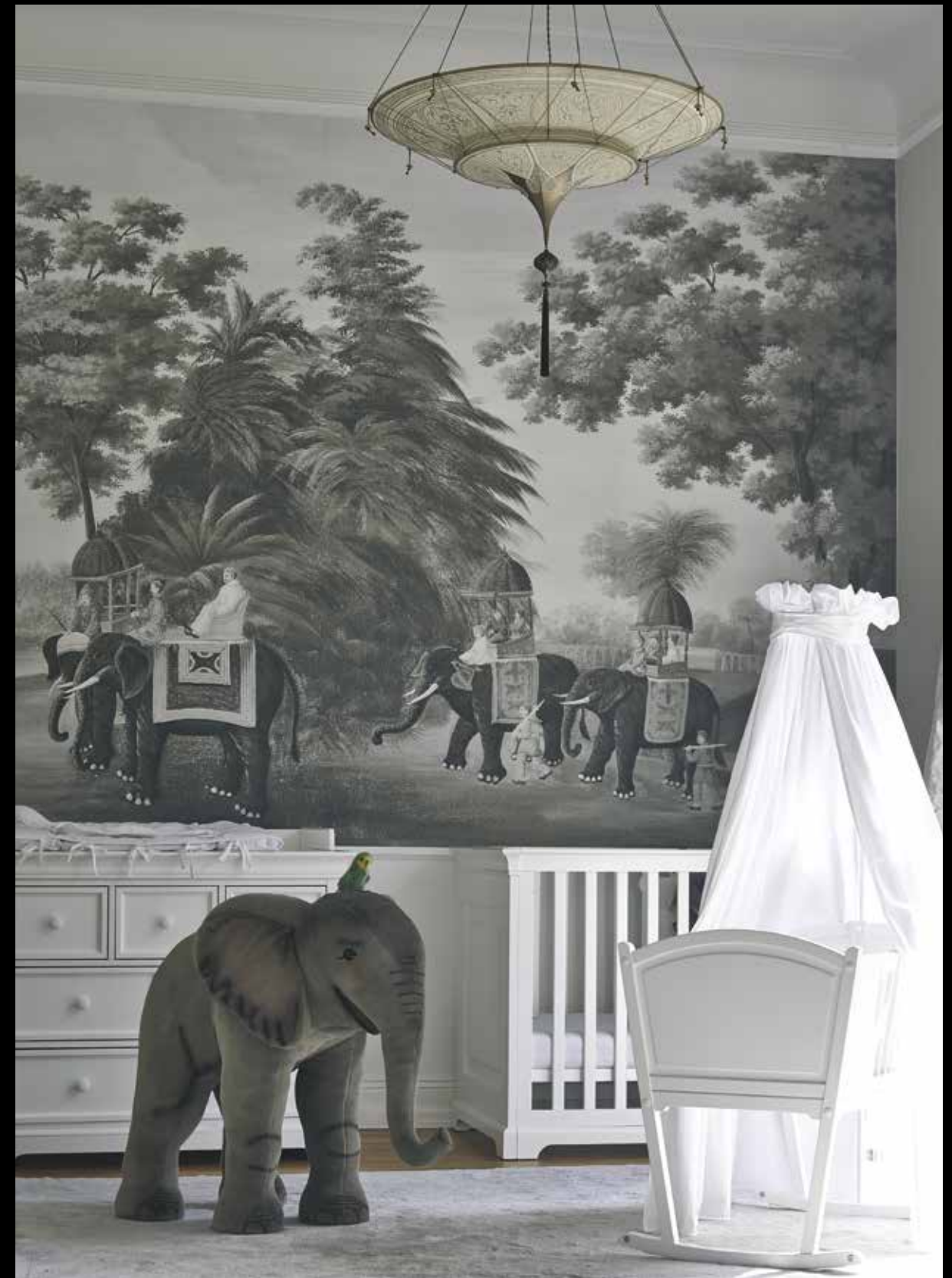

Interior Design: Julia Rafflenbeul





**Art. 086 SH**

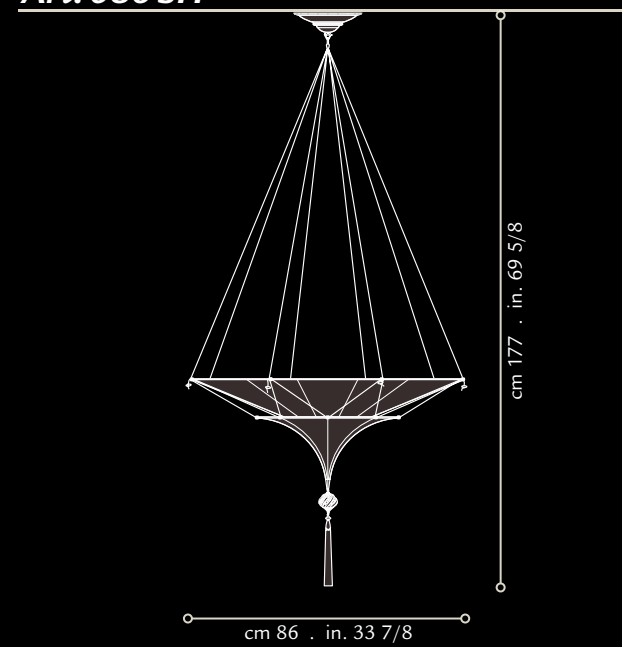

Structure: brass  
 Shade: pure silk fabric, murano glass beads  
 Weight: kg 2,2 . lb.4 oz.14  
 Wattage: suspended version 1 x max100W  
 flush mounted version 1 x max100W  
 Voltage: 1xE26 socket 110V . 1xE27 socket 220/240V  
 also suitable for LED light bulbs

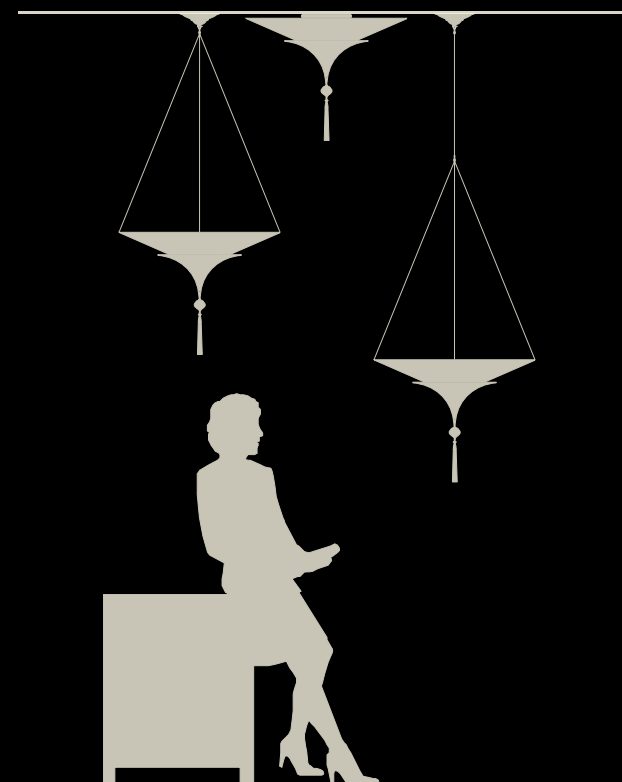

Geometric



Floral

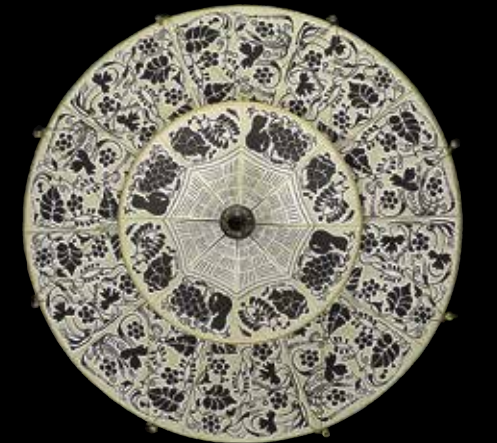

Herbarium



Plain

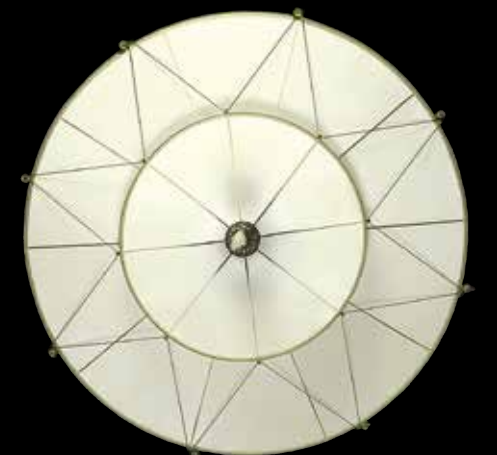



**SCHEHERAZADE 2 TIERS**  
with metal ring

In the two tiers Scheherazade, Oriental style elements combine with Venetian-Saracen decorative motifs.

The lower tier culminates with a fine engraved drop, and the Fortuny® trademark is engraved on the patterned metal ring.





**SCHEHERAZADE 2 TIERS**  
with metal ring

**Art. 125 SHC**

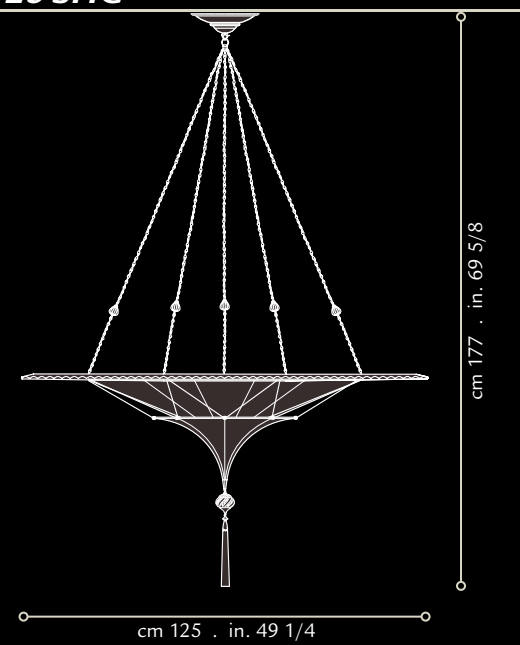

Structure: brass, burnished metal  
 Shade: pure silk fabric, murano glass beads  
 Weight: kg 9 . lb. 19 oz. 13  
 Wattage: 3 x max 100W  
 Voltage: 3xE26 socket 110V . 3xE27 socket 220/240V  
 also suitable for LED light bulbs



Geometric



Floral

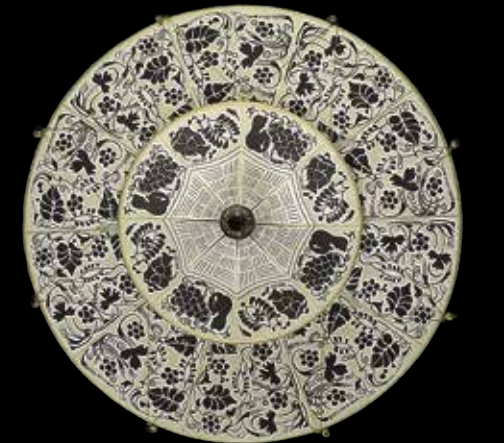

Herbarium



Plain

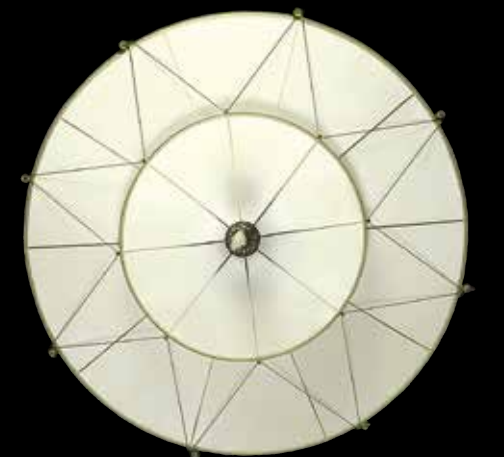





Photo: Karen Melvin

## SCUDO SARACENO

Scudo Saraceno translates to Saracen Shield – Saracen was a term used in medieval Europe to describe Muslims. This exotic design reflects Mariano Fortuny's interest in Saracen artistic themes.

The shield-like shape, decorated with Ottoman motifs and the configuration of its sections starting out from the centre, create a wonderful "sun-like" effect.

This lamp is ideal for large, sophisticated interiors. The light filters through the silk and penetrates the inlay of the decorative ring to create an evocative atmosphere.





Photo: Emanuele Tortora · Interior Design: Lago Mobili





Designer: Michelle Miller Design



Project: Le Touessrok





Courtesy of P.M. Rainon

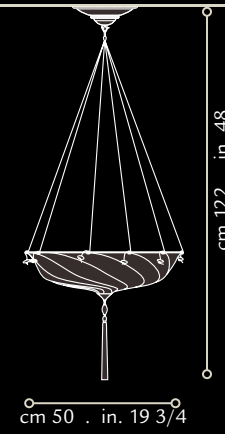

Photo: Giorgio Baroni . Interior Design: Alberto Pinto





**Art. 050SA**



**Art. 062 SA**

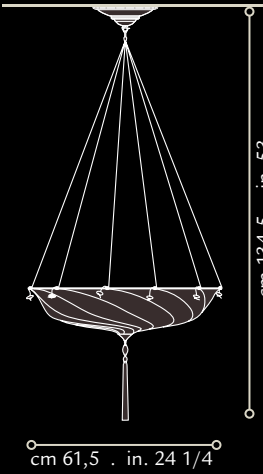

**Art. 079 SA**

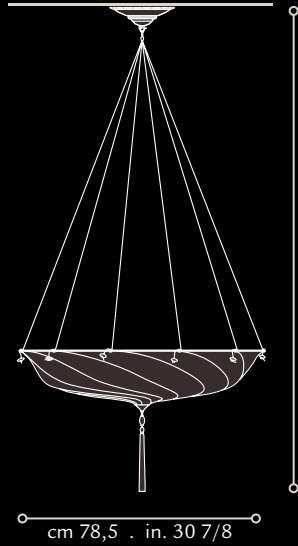

Structure: brass  
 Shade: pure silk fabric, murano glass beads  
 Weight: Ø50: kg 1,2 . lb.2 oz.10 Ø62: kg 1,5 . lb.3 oz.5  
 Ø79: kg 2 . lb.4 oz.7  
 Wattage: Ø50: 1 x max60W . Ø62: 1 x max75W  
 Ø79: 1 x max75W  
 Voltage: 1xE26 socket 110V . 1xE27 socket 220/240V  
 also suitable for LED light bulbs



Ivory Classic



Ivory Serpentine



Ivory Plain





**SCUDO SARACENO**  
with metal ring

**Art. 084 SAC**

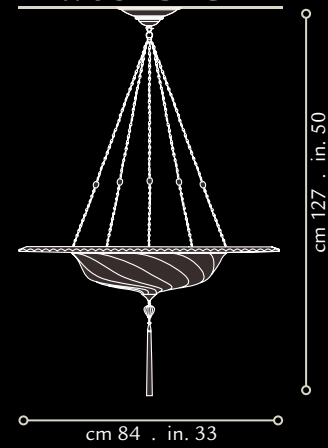

**Art. 096 SAC**

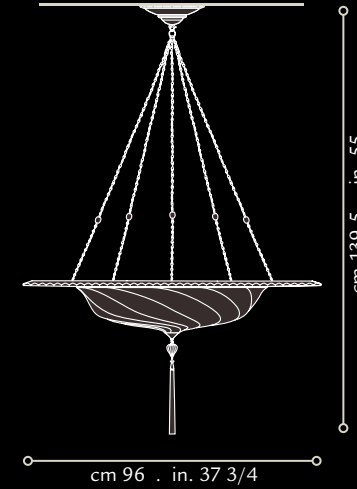

Structure: brass, burnished metal

Shade: pure silk fabric, murano glass beads

Weight: Ø84: kg 4,2 . lb.9 oz.4 Ø96: kg 6 . lb.13 oz.4

Wattage: Ø84: 1 x max60W . Ø96: 1 x max75W

Voltage: 1xE26 socket 110V . 1xE27 socket 220/240V  
also suitable for LED light bulbs

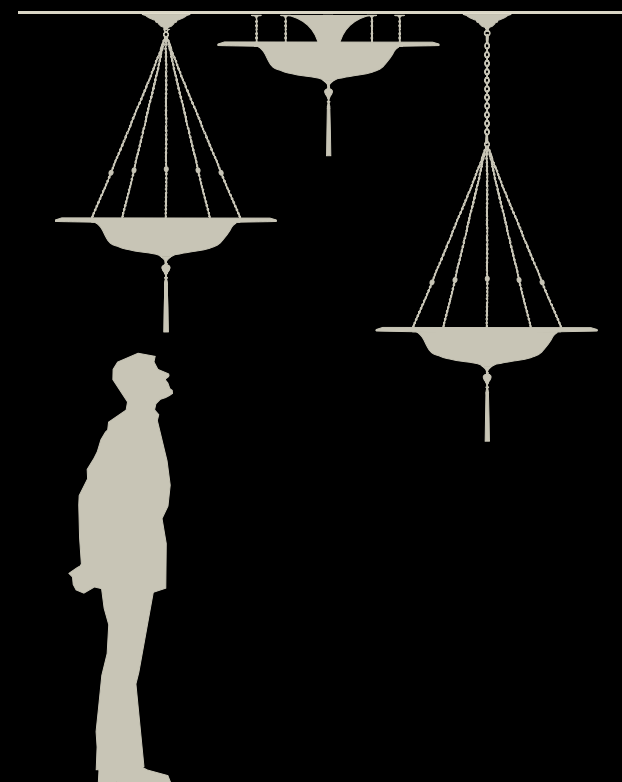

Ivory Classic



Ivory Serpentine



Ivory Plain







## SAMARKANDA

Samarkand is a city in present day Uzbekistan, and lies on the famous Silk Road trade route linking Venice and China.

This lamp's unique shape and quintessential Fortuny pattern evoke the mystique of those ancient trade journeys, and the cultural fusion they sparked.

The metal ring adds an interesting contrast of delicacy and strength.





Serpentine

Art. 037 SK

Decò

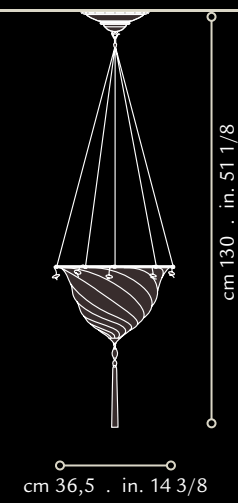

Structure: brass  
 Shade: pure silk fabric, murano glass beads  
 Weight: kg 1 . lb.2 oz.3  
 Wattage: 1 x max60W  
 Voltage: 1xE26 socket 110V  
 1xE27 socket 220/240V  
 also suitable for LED light bulbs



Plain

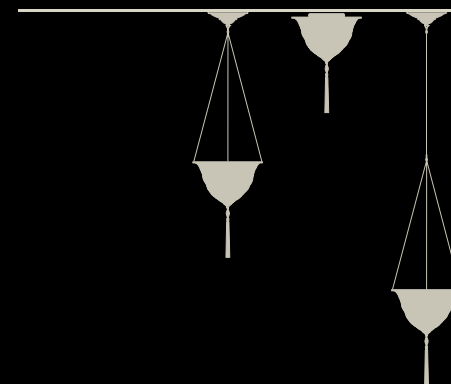





Serpentine

**SAMARKANDA**  
with metal ring

**Art. 069 SKC**

Decò

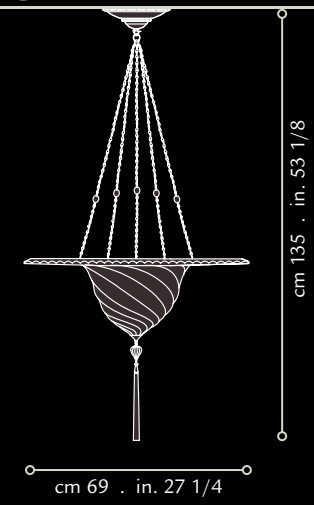

Structure: brass, burnished metal  
 Shade: pure silk fabric, murano glass beads  
 Weight: kg 2,9 . lb.6 oz.6  
 Wattage: 1 x max60W  
 Voltage: 1xE26 socket 110V  
 1xE27 socket 220/240V  
 also suitable for LED light bulbs

Plain

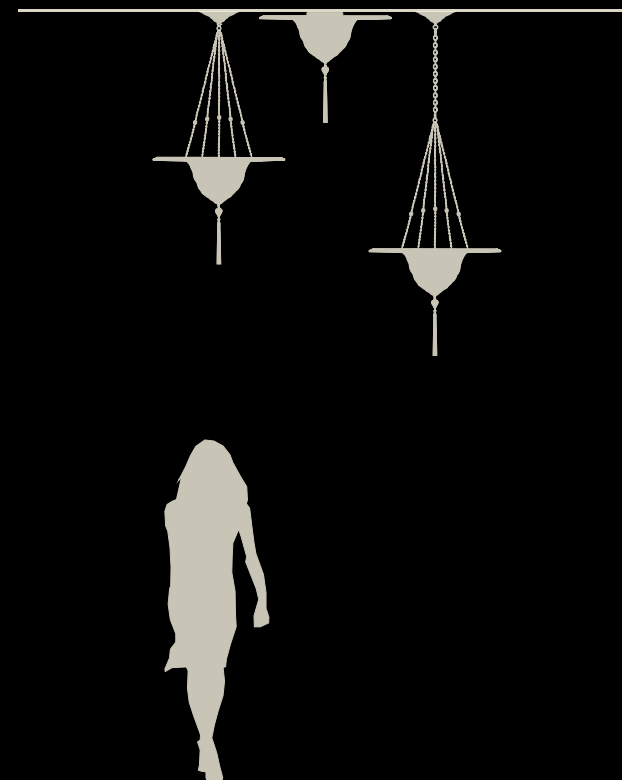





## SAMARKANDA with disk

It has a helmet-like structure, with spirals topped by an ornamental disc.

The disc is decorated with patterns suggesting a rose window in a Gothic cathedral.





**Art. 124 SD**

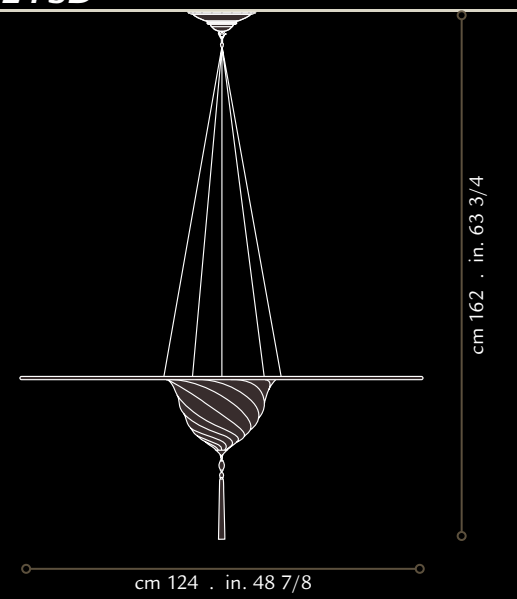

Structure: brass  
 Shade: pure silk fabric, murano glass beads  
 Weight: kg 2,5 . lb.5 oz.8  
 Wattage: 1 x max75W  
 Voltage: 1xE26 socket 110V  
 1xE27 socket 220/240V  
 also suitable for LED light bulbs

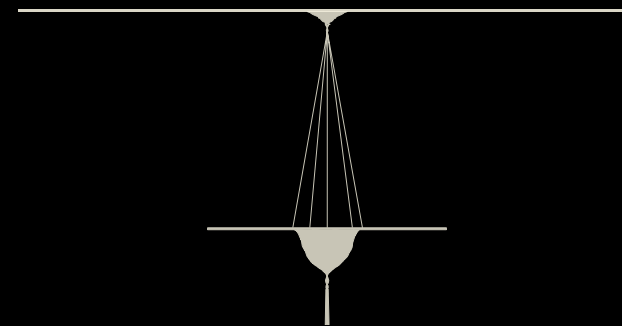

**SAMARKANDA  
with disk**



Decò



Plain





## CESENDELLO

A cesendello, or sanctuary lamp, has its roots in Rome and Byzantium, and later became popular in Venice and the Muslim world.

The profile of this elegant spiral structure recalls the twist of a turban.

The refined silhouette represents the synthesis of the Oriental and Renaissance themes present in Venice as early as the 15th century.

Cesendello floor lamp design of Mariano Fortuny's was probably the first electric floor lamp.

The elegant Cesendello silhouette is enhanced by the fabric-covered stand, which has delightful inlays.





**Art. 017 CE-1**

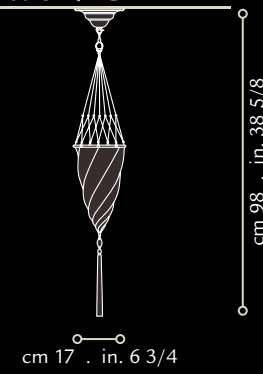

**Art. 017 CE-2**

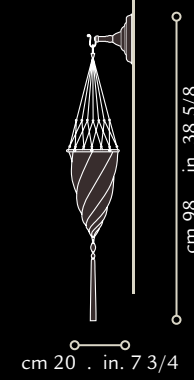

Structure: brass  
Shade: pure silk fabric, murano glass beads  
Weight: kg 0,7 . lb.1 oz.9  
Wattage: 1 x max25W  
Voltage: 1xE12 socket 110V  
1xE14 socket 220/240V  
also suitable for LED light bulbs

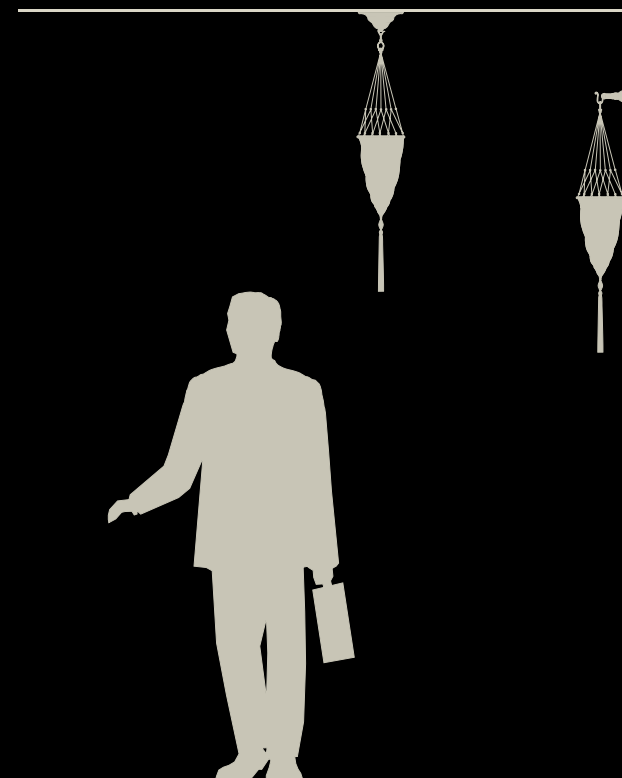



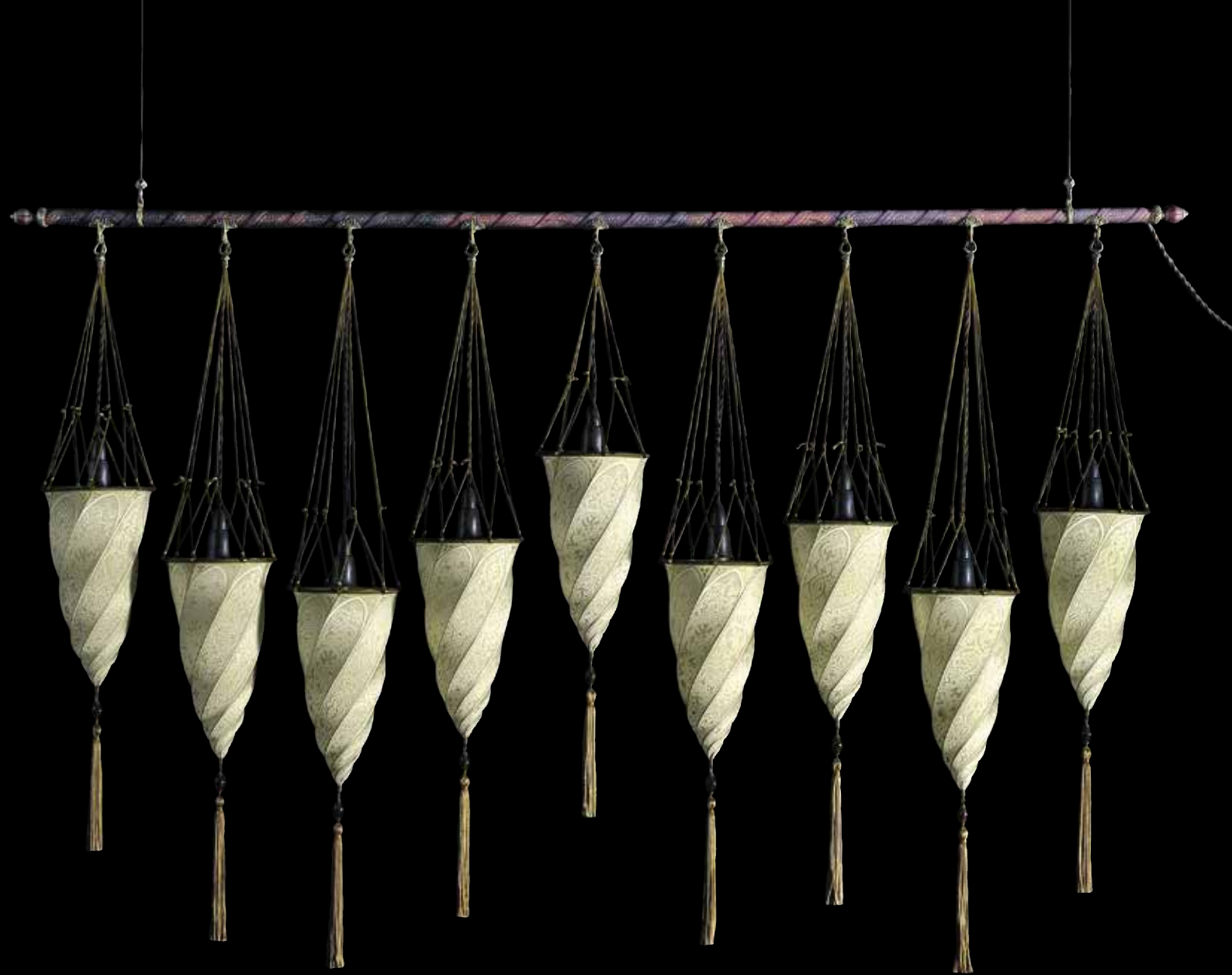

**Art. AF017-3**

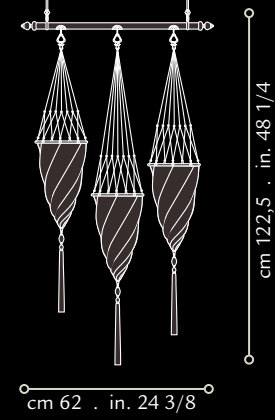

**Art. AF017-4**

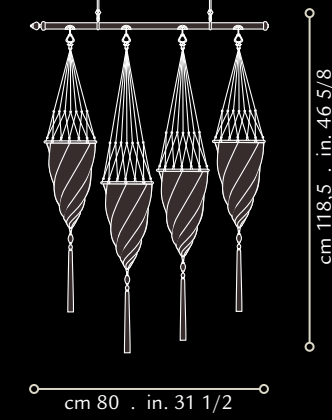

**Art. AF017-5**

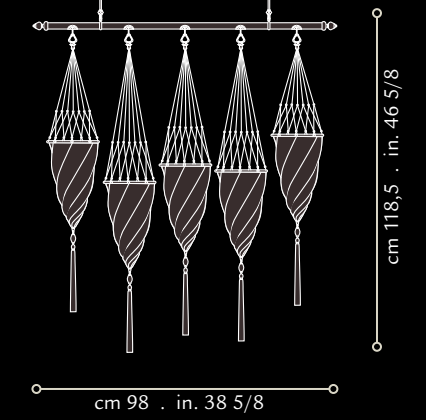

**Art. AF017-6**

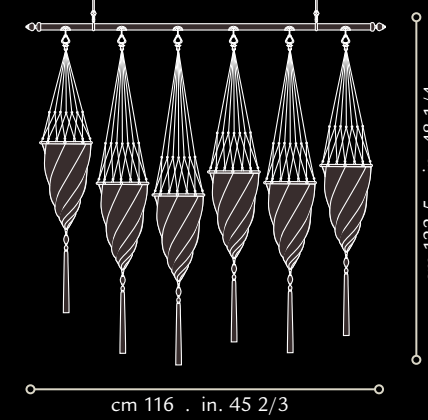

**Art. AF017-7**

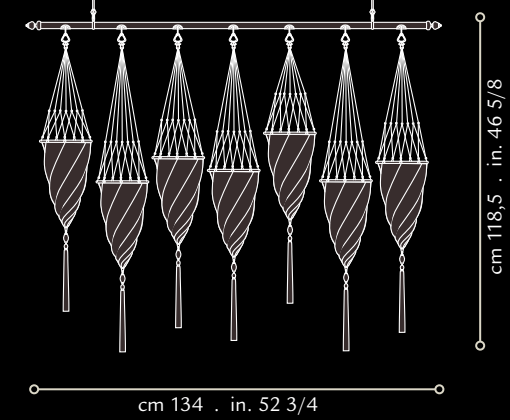

**Art. AF017-8**

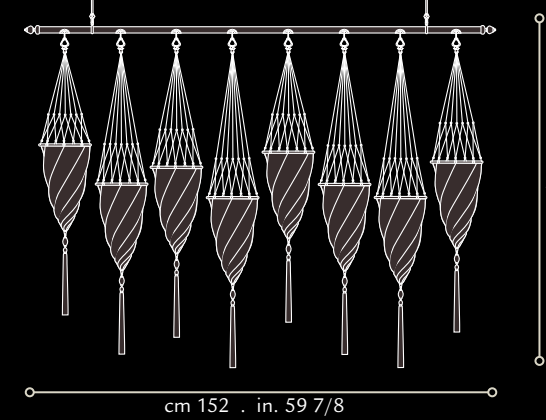

**Art. AF017-9**

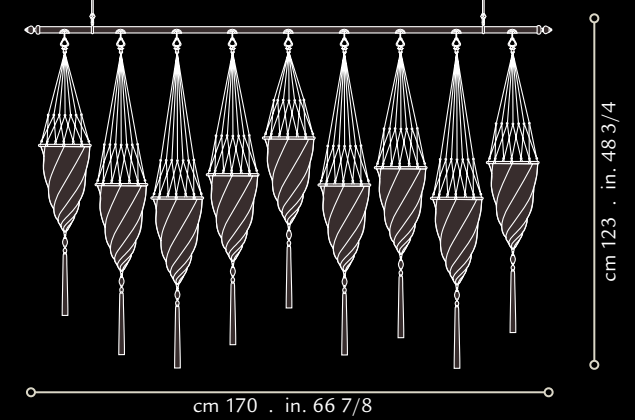

**CESNDELLI**  
on a rod

Structure: brass  
Shade: pure silk fabric, murano glass beads,  
rod covered with fabric

Weight: kg 0,5 . lb.1 oz.2 (per shade)  
Wattage: 1 x max25W(per shade)  
Voltage: 1xE12 socket 110V . 1xE14 socket 220/240V  
also suitable for LED light bulbs





red stand



green stand

**CESENDELLO**  
floor lamp

**Art. 174 ST**

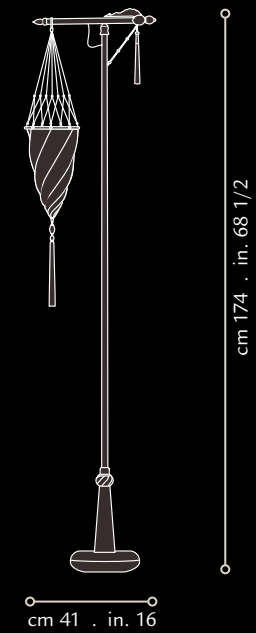

Structure: brass  
Shade: pure silk fabric, murano glass beads,  
stand covered with fabric  
Base: cast iron  
Base cover: velvet  
Weight: kg 6,5 . lb.14 oz.5  
Wattage: 1 x max25W  
Voltage: 1xE12 socket 110V  
1xE14 socket 220/240V  
also suitable for LED light bulbs

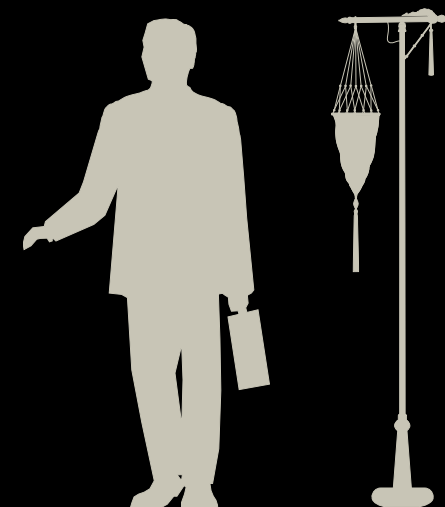





## CONCUBINE

Concubina, evokes the allure of Oriental culture, which enthralled Mariano Fortuny.

The simple wood structure protects the silk and enhances its silvery patterns

Hang this lamp individually or in a composition to achieve soft lighting that adds refinement to any décor.





**IMPERIALE**

**Art. 09 IMP**

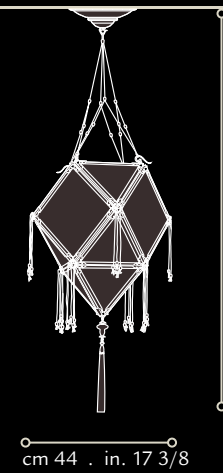

**IMPERIALE**



Structure: wood, brass, burnished metal  
 Shade: pure silk fabric, murano glass beads  
 Weight: kg 1,1 . lb.2 oz.7  
 Wattage: 1 x max75W  
 Voltage: 1xE26 socket 110V  
 1xE27 socket 220/240V  
 also suitable for LED light bulbs

**Art. 09 PRO**

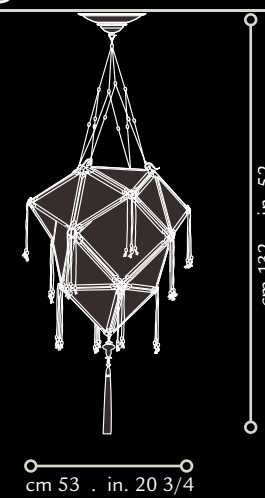

**PROIBITA**



Structure: wood, brass, burnished metal  
 Shade: pure silk fabric, murano glass beads  
 Weight: kg 1,5 . lb.3 oz.5  
 Wattage: 1 x max75W  
 Voltage: 1xE26 socket 110V  
 1xE27 socket 220/240V  
 also suitable for LED light bulbs



**Art. 09 FAV**

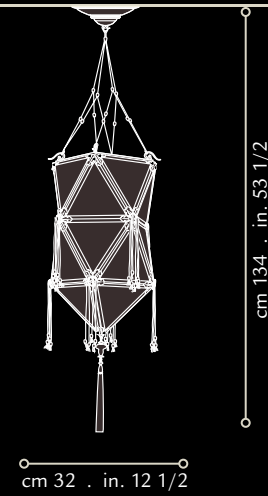

**FAVORITA**



Structure: wood, brass, burnished metal  
 Shade: pure silk fabric, murano glass beads  
 Weight: kg 1,2 . lb.2 oz.10  
 Wattage: 1 x max60W  
 Voltage: 1xE12 socket 110V  
 1xE14 socket 220/240V  
 also suitable for LED light bulbs

**Art. 09 TEM**

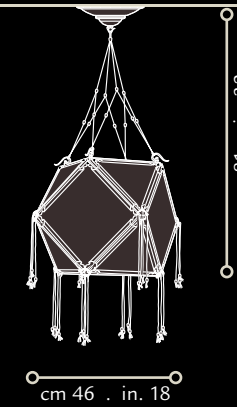

**TEMPIO**



Structure: wood, brass, burnished metal  
 Shade: pure silk fabric, murano glass beads  
 Weight: kg 0,9 . lb.1 oz.16  
 Wattage: 1 x max75W  
 Voltage: 1xE26 socket 110V  
 1xE27 socket 220/240V  
 also suitable for LED light bulbs

**Art. 09 PEO**

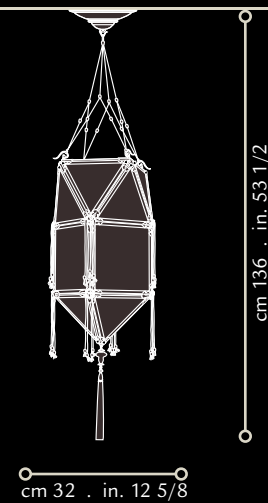

**PEONIA**



Structure: wood, brass, burnished metal  
 Shade: pure silk fabric, murano glass beads  
 Weight: kg 1,1 . lb.2 oz.7  
 Wattage: 1 x max60W  
 Voltage: 1xE12 socket 110V  
 1xE14 socket 220/240V  
 also suitable for LED light bulbs

**Art. 09 LOT**

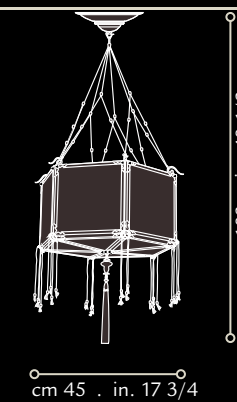

**LOTO**



Structure: wood, brass, burnished metal  
 Shade: pure silk fabric, murano glass beads  
 Weight: kg 0,9 . lb.1 oz.16  
 Wattage: 1 x max75W  
 Voltage: 1xE26 socket 110V  
 1xE27 socket 220/240V  
 also suitable for LED light bulbs





In the glass range of the FORTUNY® lamps, Venetia Studium continues the centuries-old tradition of the Venetian master glass blowers, while retaining the elegance and originality of the shapes found in the silk version.

The brilliance and transparency of the glass enhance the delicate gold decoration, made even more precious by the burnished metal of the decorative metal ring.

All models proposed are available with either a metal rim or a decorative metal ring.





## SCUDO SARACENO

Scudo Saraceno translates to Saracen Shield – Saracen was a term used in medieval Europe to describe Muslims.

This exotic design reflects Mariano Fortuny's interest in Saracen artistic themes.

This lamp is ideal for large, sophisticated interiors.

Customise this lamp to suit your aesthetic, with choice of colour, pattern and ceiling attachment.





Gold Classic

Art. G055 SA



Art. G065 SA

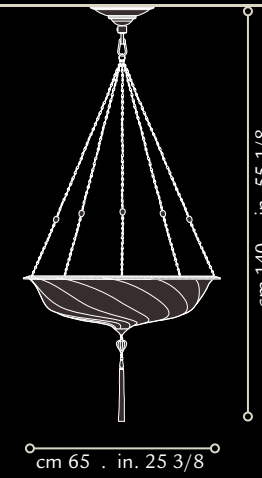

Art. G102 SA

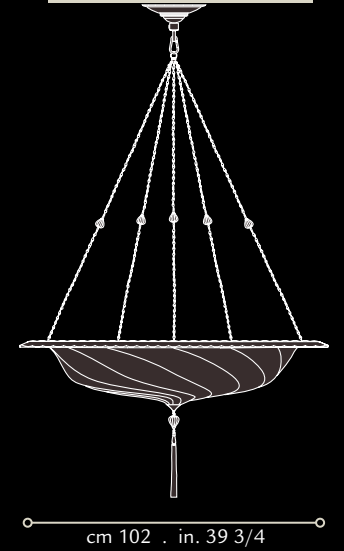

Structure: glass, brass, burnished metal, murano glass beads  
 Weight: Ø55: kg 6 . lb.13 oz.4    Ø65: kg 9 . lb.19 oz.11  
 Ø102: kg 18 . lb.39 oz.11  
 Wattage: suspended: Ø55/ Ø65: 1 x max100W  
 Ø102: 3 x max100W  
 flush mounted: Ø55/ Ø65 3 x max40W  
 Ø102: 3 x max100W  
 Voltage: E26 socket 110V . E27 socket 220/240V  
 also suitable for LED light bulbs

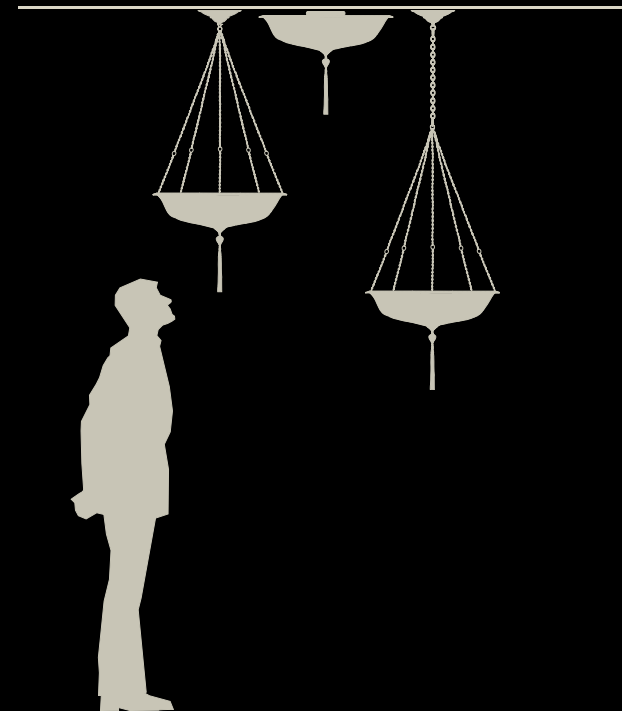

Silver Classic



White Classic



Gold Mosaic



Red Mosaic







Gold Classic

**SCUDO SARACENO**  
with metal ring

**Art. G084 SAC**

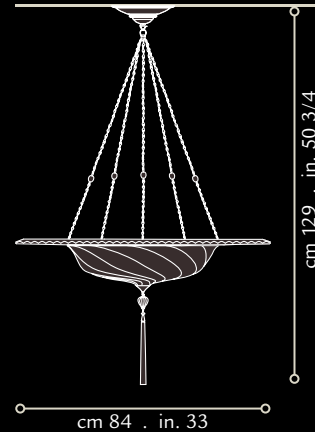

**Art. G096 SAC**

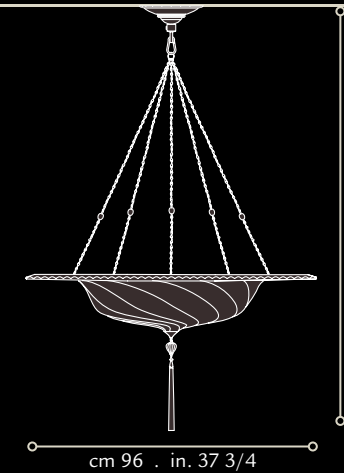

**Art. G125 SGC**

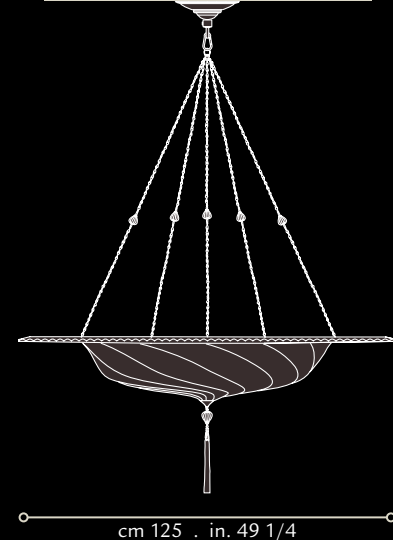

Structure: glass, brass, burnished metal, murano glass beads  
 Weight: Ø84: kg 9,5 . lb.20 oz.15    Ø96: kg 11,5 . lb.25 oz.6  
           Ø125: kg 22 . lb.48 oz.8  
 Wattage: Ø84: 1 x max100W    Ø96: 1 x max100W  
           Ø125: 3 x max100W  
 Voltage: E26 socket 110V . E27 socket 220/240V  
 also suitable for LED light bulbs

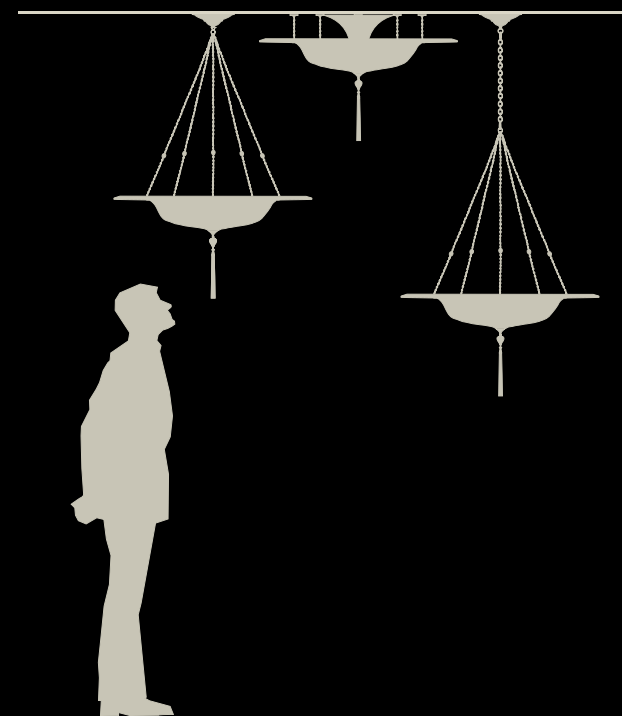

Silver Classic



White Classic



Gold Mosaic



Red Mosaic







## SAMARKANDA

Samarkand is a city in present day Uzbekistan, and lies on the famous Silk Road trade route linking Venice and China.

This wall lamp's unique shape and quintessential Fortuny pattern evoke the mystique of those ancient trade journeys, and the cultural fusion they sparked.

The light filters through the glass and penetrates the inlay of the decorative ring.





Gold Serpentine

**Art. G041 SK**



**Silver Serpentine**



Structure: glass, brass, burnished metal,  
 murano glass beads  
 Weight: kg 6 . lb.13 oz.4  
 Wattage: 1 x max100W  
 Voltage: 1xE26 socket 110V  
 1xE27 socket 220/240V  
 also suitable for LED light bulbs

**Types**

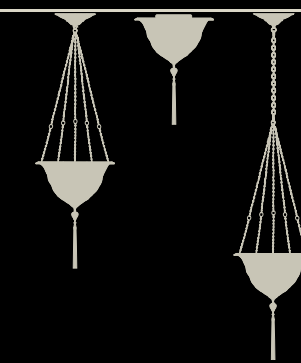

**White Serpentine**







**SAMARKANDA**  
with metal ring

**Art. G069 SKC**

Samarkanda  
with metal ring

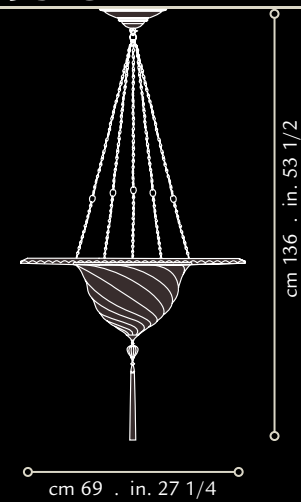

Structure: glass, brass, burnished metal  
murano glass beads  
Weight: kg 6,5 . lb.14 oz.5  
Wattage: 1 x max100W  
Voltage: 1xE26 socket 110V  
1xE27 socket 220/240V  
also suitable for LED light bulbs

**Art. G041 AP**

Samarkanda  
applique

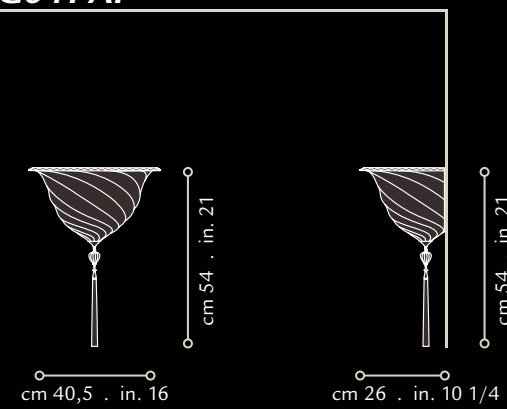

Structure: glass, brass, burnished metal  
murano glass beads  
Weight: kg 3 . lb.6 oz.10  
Wattage: 1 x max75W  
Voltage: 1xE26 socket 110V  
1xE27 socket 220/240V  
also suitable for LED light bulbs







## CESENDELLO

A cesendello, or sanctuary lamp, has its roots in Rome and Byzantium, and later became popular in Venice and the Muslim world.

The profile of this elegant spiral structure recalls the twist of a turban.

The refined silhouette represents the synthesis of the Oriental and Renaissance themes present in Venice as early as the 15th century.

Choose from 6 patterns: gold mosaic, red mosaic, white, gold and silver.

The Cesendello Cascade is available in 33-shade and 25-shade compositions.





Gold Classic

CESENDELLO

Art. G019 CE-1

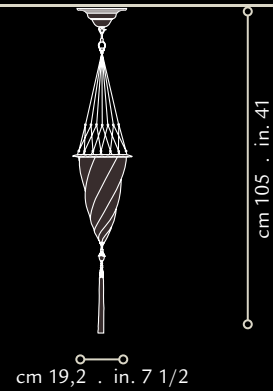

Art. G019 CE-2

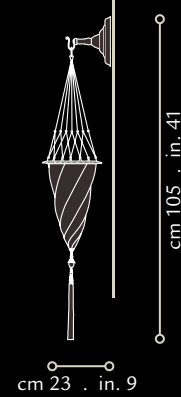

Structure: glass, brass, burnished metal  
 murano glass beads  
 Weight: kg 2,3 . lb.5 oz.1  
 Wattage: 1 x max60W  
 Voltage: 1xE12 socket 110V  
 1xE14 socket 220/240V  
 also suitable for LED light bulbs

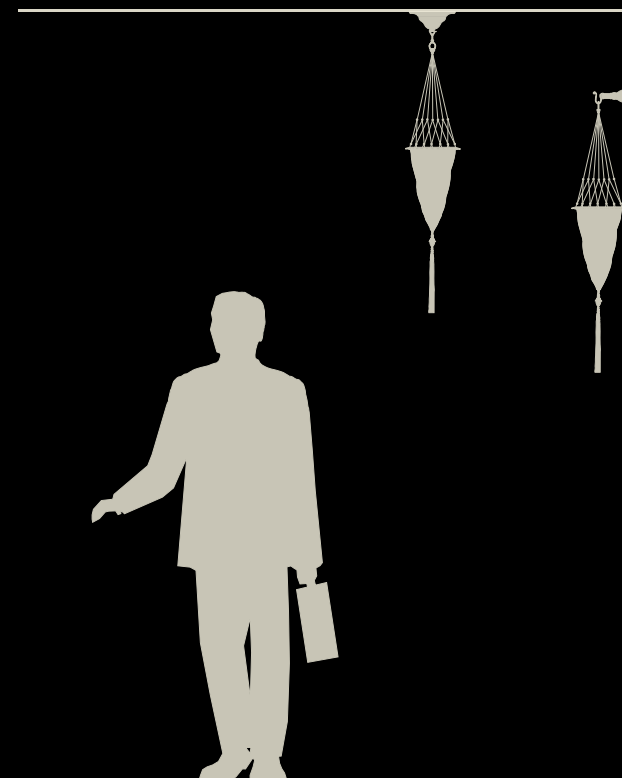

Silver Classic

White Classic



Gold Mosaic

Red Mosaic







**CESENDELLO**  
with metal ring

Gold Classic

**Art. G029 CEC-1**

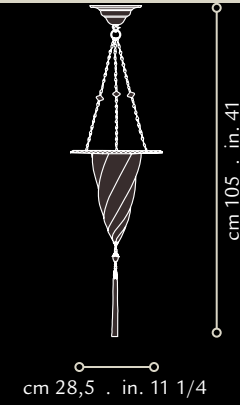

**Art. G029 CEC-1**

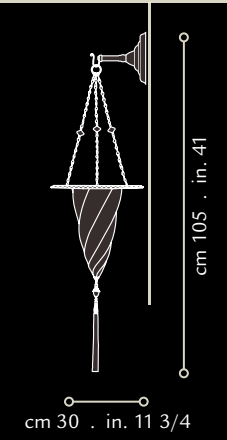

Cesendello  
with metal ring



Structure: glass, brass, burnished metal  
murano glass beads  
Weight: kg 2,6 . lb.5 oz.12  
Wattage: 1 x max60W  
Voltage: 1xE12 socket 110V  
1xE14 socket 220/240V  
also suitable for LED light bulbs

**Art. G019 AP**

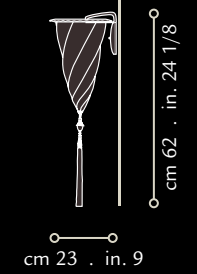
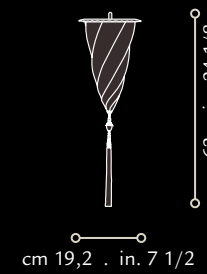

Cesendello  
applique



Structure: glass, brass, burnished metal  
murano glass beads  
Weight: kg 2,3 . lb.5 oz.1  
Wattage: 1 x max60W  
Voltage: 1xE12 socket 110V  
1xE14 socket 220/240V  
also suitable for LED light bulbs





**CESENDELLO**  
arc wall triple

**Art. GCM 019-3**

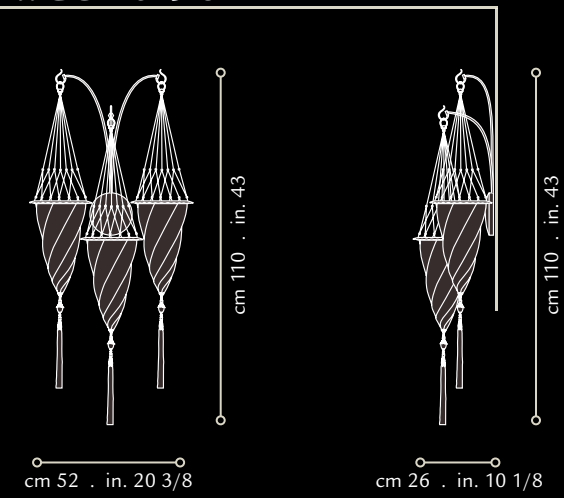

Structure: glass, brass, burnished metal  
 murano glass beads  
 Weight: kg 7 . lb.15 oz.7  
 Wattage: 1 x max60W (per shade)  
 Voltage: 1xE12 socket 110V  
 1xE14 socket 220/240V  
 also suitable for LED light bulbs

Cesendello  
arc wall triple



**Art. GCM 019-1**

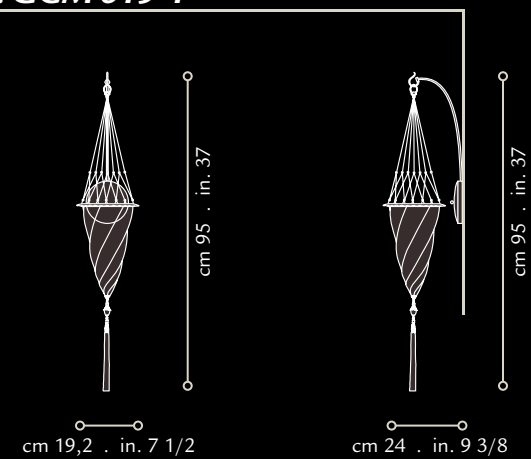

Structure: glass, brass, burnished metal  
 murano glass beads  
 Weight: kg 3,6 . lb.7 oz.15  
 Wattage: 1 x max60W  
 Voltage: 1xE12 socket 110V  
 1xE14 socket 220/240V  
 also suitable for LED light bulbs

Cesendello  
arc wall







**Art. GAF019-3**

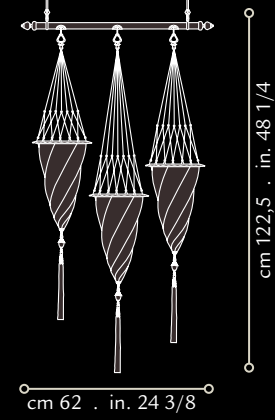

**Art. GAF019-4**

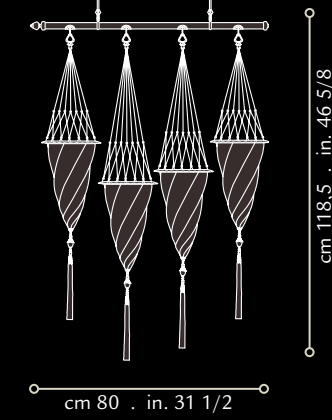

**Art. GAF019-5**

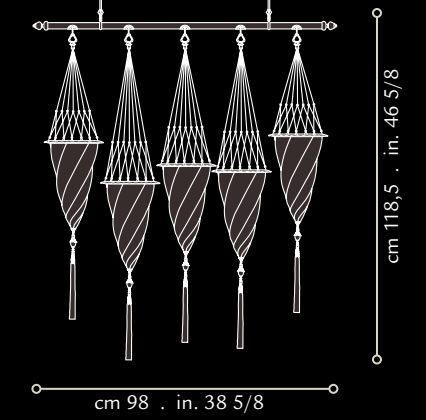

**Art. GAF019-6**

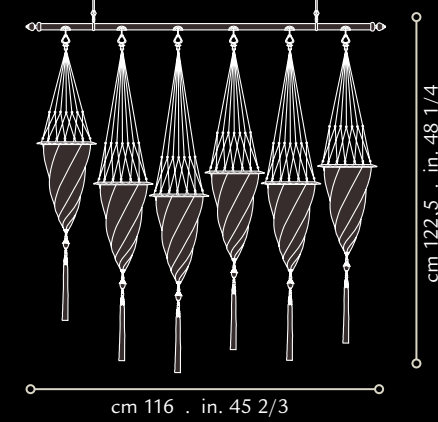

**Art. GAF019-7**

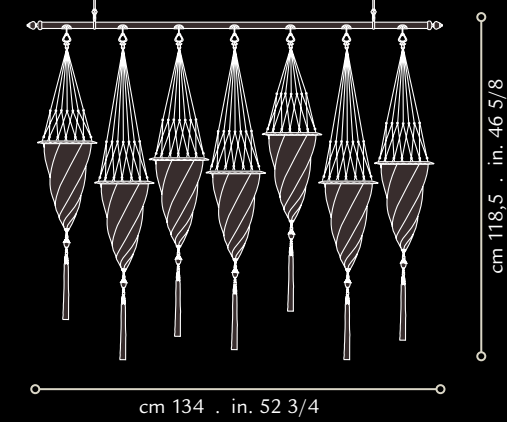

**Art. GAF019-8**

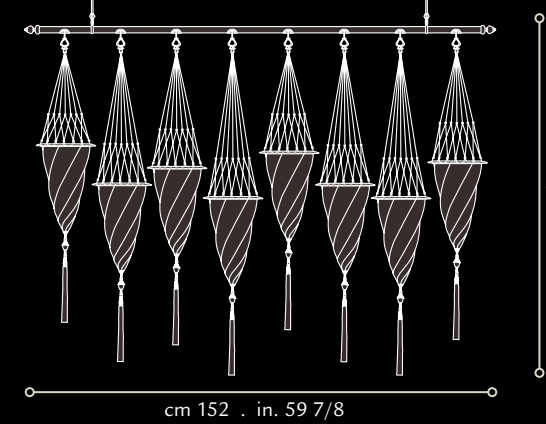

**Art. GAF019-9**

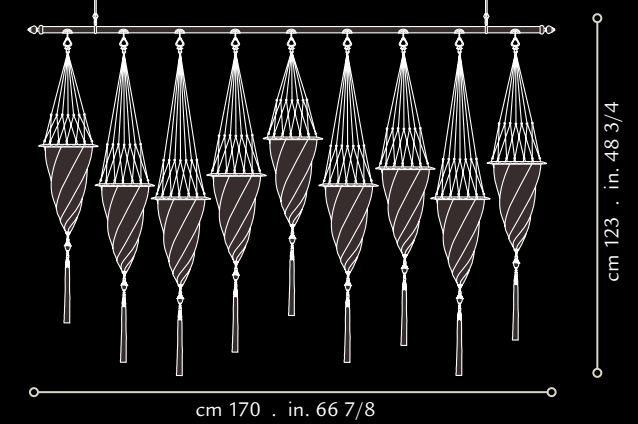

**CESNDELLI**  
on a rod

Structure: glass, brass, burnished metal,  
murano glass beads  
rod covered with fabric

Weight: kg 1,9 . lb.4 oz.3 (per shade)  
Wattage: 1 x max60W (per shade)  
Voltage: 1xE12 socket 110V . 1xE14 socket 220/240V  
also suitable for LED light bulbs





red stand



green stand

**CESENDELLO**  
floor lamp

**Art. G174 ST**

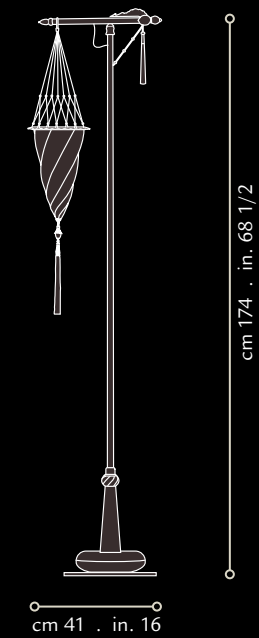

Structure: glass, brass, burnished metal,  
murano glass beads,  
stand covered with fabric  
Base: cast iron  
Base cover: velvet  
Weight: kg 8 . lb.17 oz.10  
Wattage: 1 x max60W  
Voltage: 1xE12 socket 110V  
1xE14 socket 220/240V  
also suitable for LED light bulbs

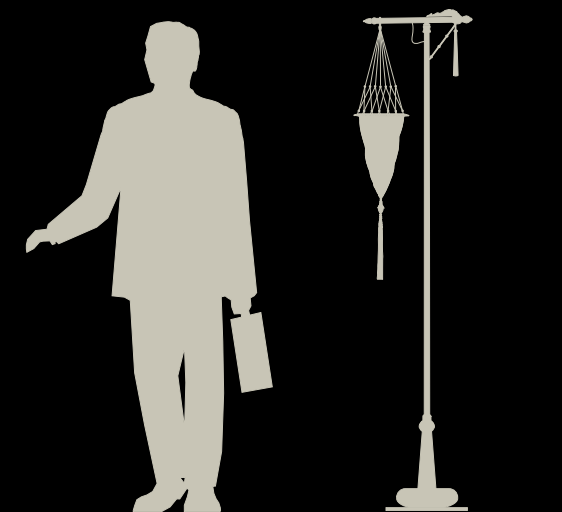



**SUSPENDED COMPOSITION**  
**33 cesendello**

**Art. GCM019-33**

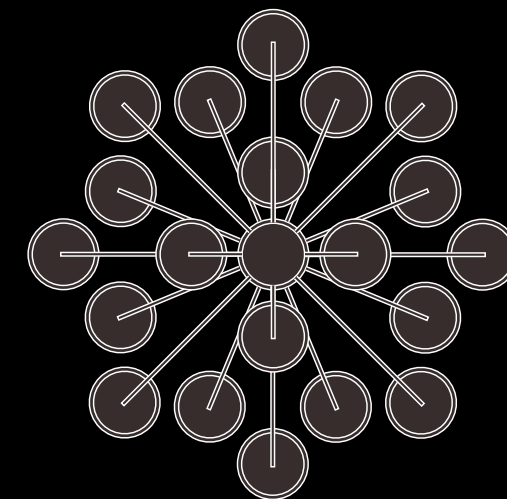
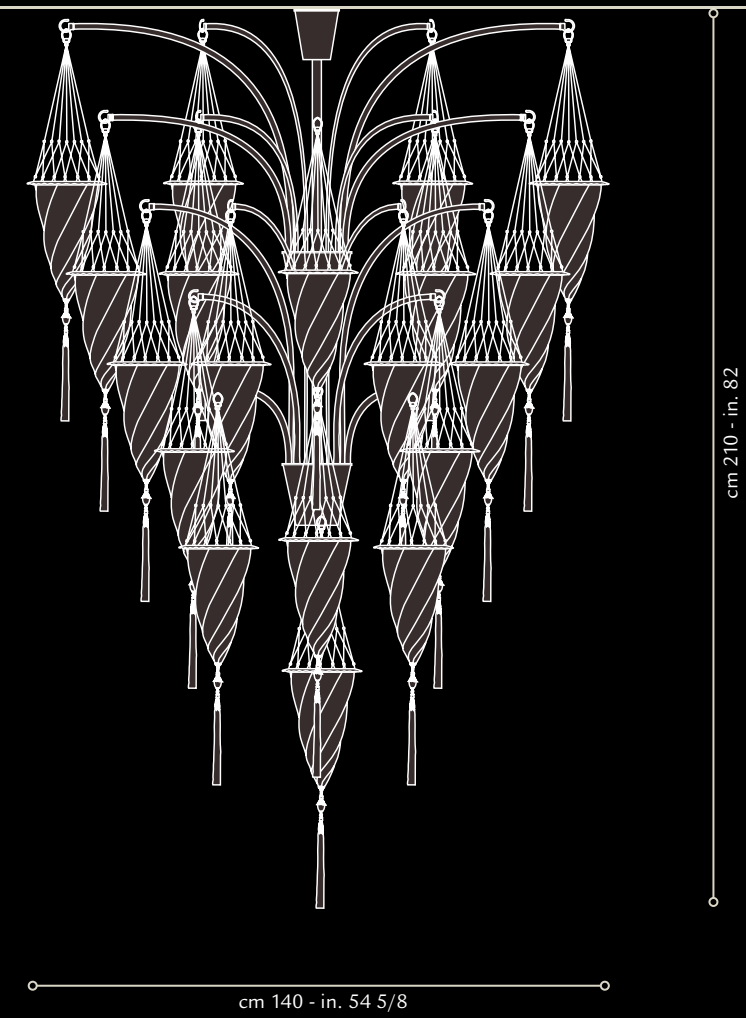

Structure: glass, brass, burnished metal,  
 murano glass beads

Weight: kg 70 . lb.154 oz.5  
 Wattage: 33 x max 40W  
 Voltage: E12 socket 110V . E14 socket 220/240V  
 also suitable for LED light bulbs





**CEILING COMPOSITION**  
**9 cesendello**

**Art. GCM 019-9**

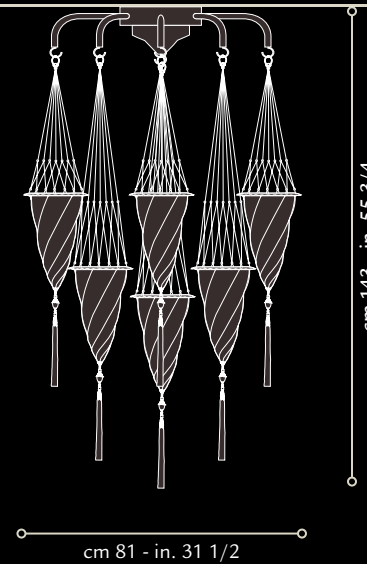

ceiling composition  
9 cesendello

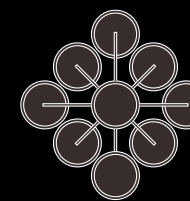

**Art. GCM 019-7**

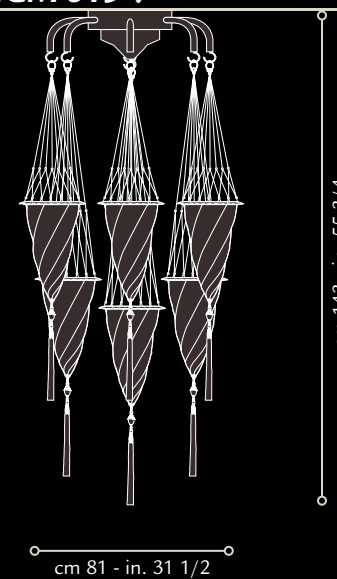

ceiling composition  
7 cesendello

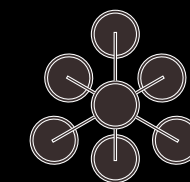

**Art. GCM 019-5**

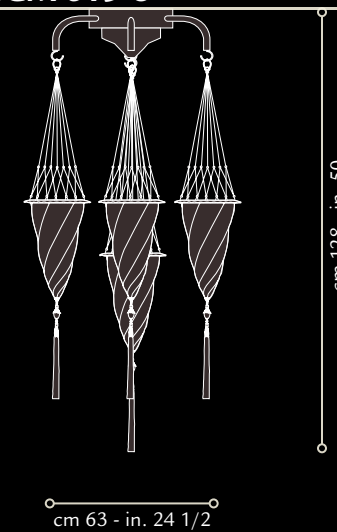

ceiling composition  
5 cesendello

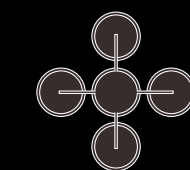

Structure: glass, brass, burnished metal,  
murano glass beads

Weight: kg 1,9 . lb.4 oz.3 (per shade)  
Wattage: 1 x max 60W (per shade)  
Voltage: E12 socket 110V . E14 socket 220/240V  
also suitable for LED light bulbs



## MARIANO FORTUNY

Artist, photographer, designer... it is hard to single out which aspect of the personality and work of Mariano Fortuny was predominant.

His entire artistic production was based on an extraordinary synthesis of worlds and eras, of styles and techniques that only in Venice, a melting pot of civilizations, could be transformed into the creation of exquisite products.

Through philological experimentation inspired by the noble roots of Western art and the magic of the Orient, Mariano Fortuny became one of the most original interpreters of Venice's "Silver Age".

His constant research into lighting led him to file a number of patents, including a device to control light intensity, used in the world's most prestigious theatres.



Design protected.

The original FORTUNY® lamps are produced exclusively by Venetia Studium, the only company in the world entitled to use the trademark.

On request, all our lamps can be produced for North America according to UL\* standards and for Europe according to CE standards.

The company reserves the right to modify its products without warning. Colours and patterns may differ slightly from the ones featured in this catalogue.

No part of this work may be reproduced or transmitted in any form or by any means without prior permission. All rights reserved. Made in Venice - Italy

\*with the exception of floorstand and rod.



# FORTVNY®

[www.fortuny.it](http://www.fortuny.it)  
[info@fortuny.it](mailto:info@fortuny.it)

Produced & Distributed by:

VENETIA STUDIUM S.r.l.

San Marco, 2425 30124 Venezia - Italy

T. +39 (0)41 523 6953 F. +39 041 522 7353

[info@venetiastudium.com](mailto:info@venetiastudium.com)

Shops:

FORTUNY sas

San Marco, 2428 30124 Venezia - Italy

T. +39 (0)41 5200 505

[venice@fortuny.it](mailto:venice@fortuny.it)

FORTUNY sas

Dorsoduro, 180/A 30123 Venezia - Italy

T. +39 (0)41 5210 187

[venice@fortuny.it](mailto:venice@fortuny.it)

FORTUNY sas

17, rue Bonaparte 75006 Paris, France

T. +33 (0)1 43 29 85 74

[paris@fortuny.fr](mailto:paris@fortuny.fr)



